

Smart Crane System
ELEVALL®

EK 400

NEW PATENTED
SYSTEM

The future of construction logistics
El futuro de la logística de construcción



NEW MODEL EK400

NUEVO MODELO EK400



The new model EK400 is a revolution for lifting windows, awnings, pergola, glass, aluminium, furniture and construction materials

El nuevo modelo EK400 es una revolución para elevar ventanas, toldos, pérgolas, vidrios, aluminio, muebles y materiales de construcción.

COMPACT DESIGNED DISEÑO COMPACTO

Thanks to its compact size it fits in any elevator

Gracias a su tamaño compacto cabe en cualquier ascensor

The battery-powered motorized wheels make it easy to transport and load into vehicles.

Sus ruedas motorizadas a batería facilitan el transporte y la carga en los vehículos



GREAT WORK CAPACITY GRAN CAPACIDAD DE TRABAJO

With a 3 HP motor it can lift 400 kg/881 lb.

**Con un motor de 3 CV de potencia
puede elevar 400 kg/881 lb.**



**Maximum height capacity of 100 m./328 Ft.
Máxima capacidad de altura de 100 m./328 Ft.**



ELECTRONIC SECURITY SEGURIDAD ELECTRONICA



**With single-phase voltages of 110v 60hz.
Or 220v. 50Hz
Con voltajes monofásicos de 110v 60hz. O
220v. 50 Hz**

**Our new hoists are equipped with variable frequency
drives with soft start-stop.**

**Nuestros nuevos motores vienen provistos con Variadores
de frecuencia con start-stop suave.**



IMPROVEMENTS MEJORAS



Double Brake & hidrahulic pistón
Doble freno & pistón hidráulico



Support weel
Rueda de asistencia

TWO CRANES IN ONE DOS GRÚAS EN UNA

**Balcony anchor system
Anclaje techo balcón**



**Counterweights
Contrapesos**

VERSATILITY

VERSALİTİDAD

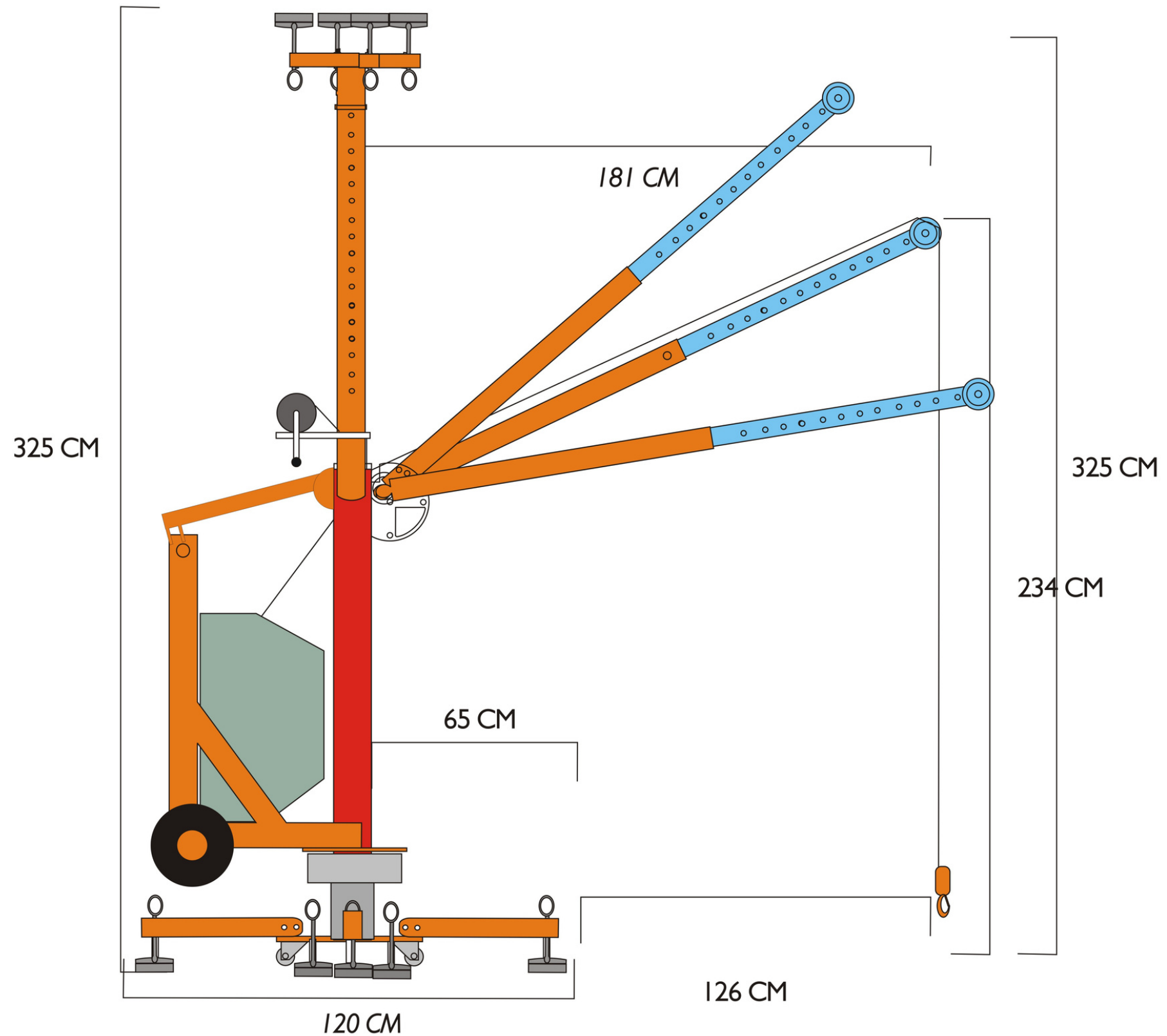

Great ability to adapt in any situation.
Gran capacidad de adaptación en cualquier situación.

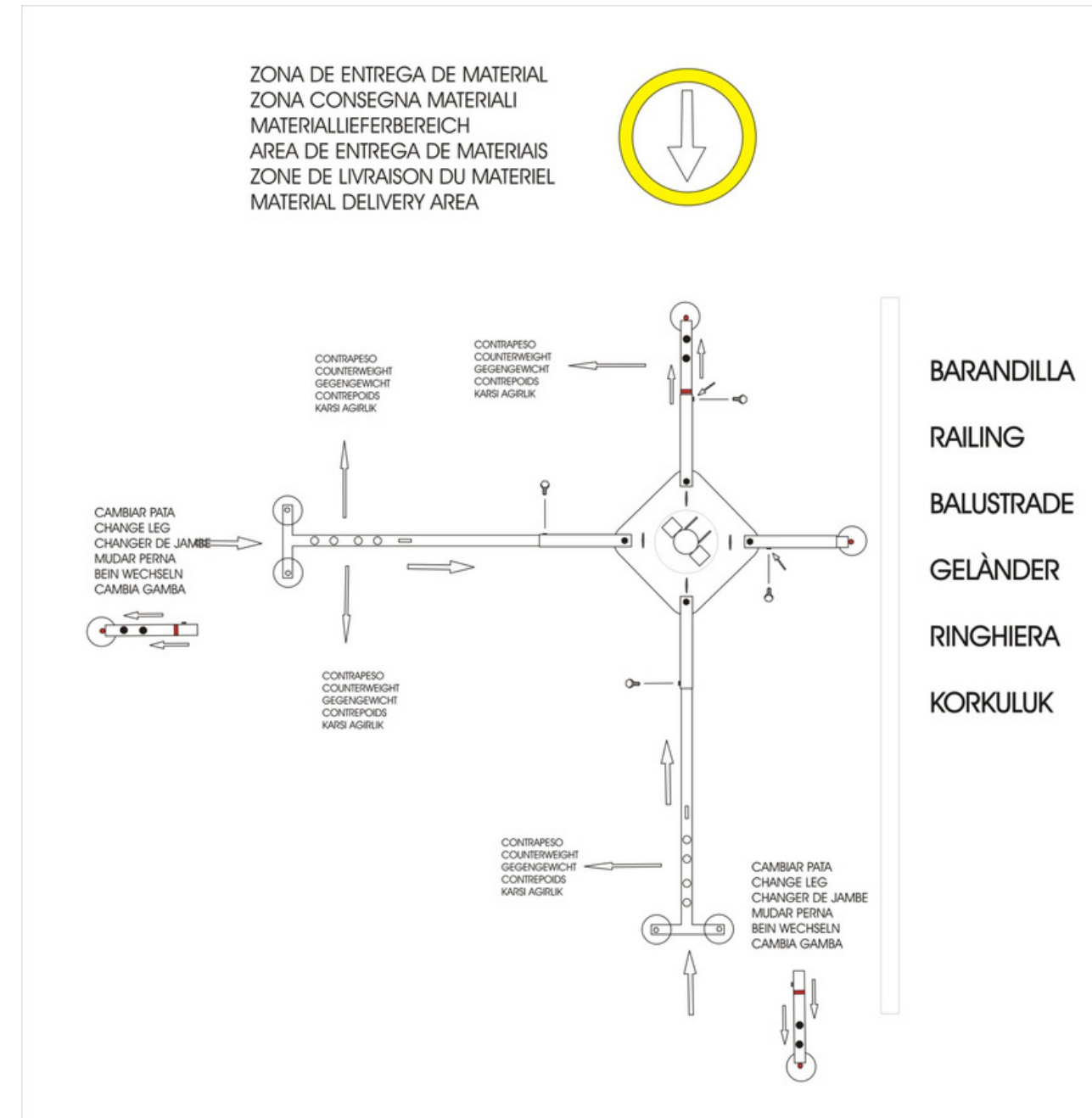

EUROPEAN CERTIFIED PRODUCTS PRODUCTOS EUROPEOS CERTIFICADOS

All our products comply with safety regulations and are certified in addition to complying with ISO 9001 regulations.

Todos nuestros productos cumplen con la normativa de seguridad y son certificados además de cumplir con la normativa ISO 9001



ELEVALL[®]

elevall.com | 34 667 672 558 | info@elevall.com



You **Tube**

